



RC PUBLIC ART

CALL FOR ARTIST - REQUEST FOR QUALIFICATIONS

Mini Mural Project

Please read and review ALL application materials before applying.

Call Summary

The City of Rancho Cucamonga is issuing a Request for Qualifications from artists, or artist teams, to design and install mini mural projects on select cement directional markers along the Pacific Electric Trail, located in Rancho Cucamonga, CA. The mini murals will be located at key intersections along the Pacific Electric Trail and visible to vehicle, pedestrian, and bicycle traffic.

The project goals for the Mini Mural Project along the Pacific Electric Trail are to enhance the route's aesthetic appeal, promote local artists, and provide a surprise and delight opportunity for community members. These murals will support the implementation of the RC Public Art Plan by placing art along a community-identified priority area and establishing the City's art mural program. The Mini Murals will beautify the trail and foster a sense of connection and community pride by further enhancing a beloved community green space.

We invite professional artists 18 years and older to submit their qualifications for this project.

Estimated Timeline

- Application Submission Deadline: October 22, 2023, by 11:59 p.m. (PDT)
- Project Timeline:
 - RFQ Release: September 20, 2023
 - Pre-approval meeting/Zoom discussion workshop for interested Artists: October 11*
 - Application Submission Deadline: 11:59 p.m. (PDT) on October 22, 2023, or until 100 applications have been received
 - Art Selection Panel review October 25 – November 1, 2023
 - Artist interviews (if required) November 6 – 15, 2023
 - Selected finalists notified: November 20 – 23
 - Concept development and review: November 27 – January 15
 - Project(s) Installed: February 2024*

Budget: Selected artist(s) will receive a \$1,000 stipend per directional marker for the design, fabrication, and installation of the work.

Geographic Eligibility Requirements: This is an open call, but preference will be given to artists who work, reside, or attend school in Rancho Cucamonga or the surrounding area.

Project Site Description

The Pacific Electric Trail (PET) is a free public access trail designed for walking, cycling, and equestrian uses that spans 21 miles from Claremont, CA, to Rialto, CA, approximately 8 miles of which is in Rancho Cucamonga, CA. The trail was developed as a Rails-to-Trails project and is a vital recreation corridor supporting access to safe green space in our community and the City's goal of improving the quality of life among residents. During the RC Public Art community engagement process, the Pacific Electric Trail emerged as a high-priority area for public art placement. Infusing this vibrant trail with public art will not only enhance its aesthetic appeal but will support the City's placemaking efforts and inspire community pride and engagement. The Pacific Electric Trail, with its blend of recreation, represents a dynamic force in shaping a more vibrant and cohesive community for us all.



Mini Mural Project Site Scope

The scope of the Mini Mural Project includes designing and painting two sides of the directional marker measuring approximately 18" wide and 36" tall and the top of the directional marker measuring about 20" by 20"; see the measurement guide below for reference.

Mini Mural Project Measurements Guide

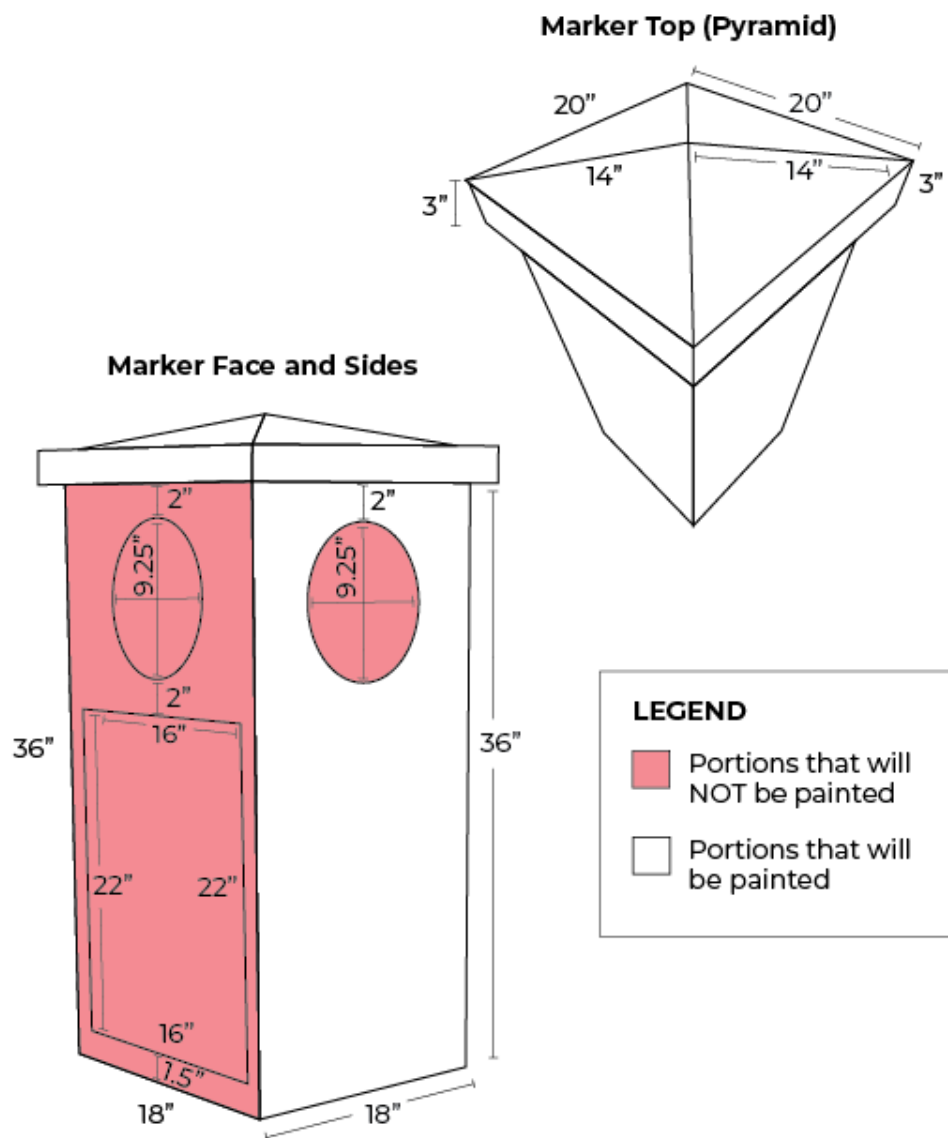



The project will cover five (5) intersection locations with two markers at each intersection. Locations include:

- [Pacific Electric Trail @ Hellman Avenue](#)
- [Pacific Electric Trail @ Base Line Road](#)
- [Pacific Electric Trail @ Hermosa Avenue](#)
- [Pacific Electric Trail @ Haven Avenue](#)
- [Pacific Electric Trail @ Kenyon Way](#)

Artist Eligibility

- Artists must be 18 years or older to apply
- Application is open to professional artists
- Preference will be given to artists who reside in the Inland Empire region

Budget

- Artists will be awarded a \$1,000.00 stipend per directional marker; this is inclusive of all artist design fees, supplies, fabrication, and time spent
- Selection and funding are contingent upon a signed agreement between the artist and the City of Rancho Cucamonga. The stipend will be distributed in two payments: \$300 for the completion of the artwork design concept and \$700 to be paid upon the completed installation of the artwork



Application Submission and Review Process:

This is an online-only application process. Incomplete applications will not be reviewed. All materials must be submitted online via the CaFÉ™ website (www.callforentry.org). There is no application fee to apply or to use the CaFÉ™ system. To view the application, go to www.callforentry.org, register a username and password, navigate to “Apply to Calls,” and search the list for “City of Rancho Cucamonga Mini Mural Project.”

For consideration, the application must include the following:

1. Artist Statement of Interest (750 words maximum)

- What is your connection to the Pacific Electric Trail, or more broadly to recreational trails, and how has it influenced your interest in the Mini Mural Project?
- Describe your experience creating public art murals and why you believe your work would be appropriate for this project.
- Describe your process for incorporating community input in the design and/or creation of art projects.
- Describe how you would complete the project goals within the outlined budget and timeline.

Artist Statement of Interest will be reviewed based on the following:

- Ability to effectively communicate their connection to outdoor spaces and the influence it has on their interest in the project.
- Demonstrated ability to undertake and successfully execute the work in accordance with the project goals and timeline, in a professional manner, and within the project budget.

2. Professional Resume + References (1,500 words maximum)

- Submission must include a current resume that outlines your professional accomplishments as an artist.
- Three Professional References: Contact information for references should include name, title and affiliation, phone number, and email address.

Resume and references will be reviewed based on the following:

- Range of experience and professional commitment.
- Indication of artist(s)'s ability to plan and realize public art projects or artwork of a similar scope.

3. Images and description of previous work, digital images (minimum of five, maximum of 10) of recent previous work (created within the past 10 years)

- Each image should include title, year, media, location, project budget, dimensions, commissioning agency, and collaborators or design professionals (if applicable). Files should be titled LastnameFirstname_projectname

Images and descriptions of previous work will be reviewed based on the following:

- A relevant body of work that demonstrates professional and artistic qualifications and standards of excellence, creativity, and originality of style, as well as the appropriateness of the applicant's style to the project.
- Descriptive information for each image is provided as requested.
- Clarity of translation of the artistic concept into art form.
- High-quality images that accurately represent your work.



Artist Selection Process

- October 23 – 25: City Staff will pre-screen submittals from artists for compliance with project requirements
- October 25 – November 1: The Art Selection Panel will review qualifying artist(s) submissions via CaFÉ and select a pool of Artists for interviews with the Art Selection Panel
- November 6 – 15: Selected Artists will complete virtual interviews to discuss the project goals and review any art selection panel questions regarding their qualifications for the project
- November 15 – November 20: The Art Selection Panel will make final recommendations to the City for up to five (5) artists to move to the art design phase

Estimated Timeline*

- Application Submission Deadline: October 22, 2023, by 11:59 p.m. (PDT)
- Project Timeline:
 - RFQ Release: September 20, 2023
 - Pre-approval meeting/Zoom discussion workshop for interested Artists: October 11 @ 6:00 pm PDT
 - Application Submission Deadline: 11:59 p.m. (PDT) on October 22, 2023, or until 100 applications have been received
 - Art Selection Panel review October 25 – November 1, 2023
 - Artist interviews (if required) November 6 – 15, 2023
 - Selected finalists notified: November 20 – 23
 - Concept development and review: November 27 – January 15
 - Project(s) Installed: February 2024

****All dates are subject to change at the City of Rancho Cucamonga's discretion***

The artist cannot begin the mural installation until the design is approved and all required liability and contract forms are completed and submitted to the City.

Point of Contact

For questions about the application, please email PublicArt@cityofrc.us